

English Ver.

KAWATA

COMPANY PROFILE



Open the Way to the Future of Advanced Material Development through the Powder & Granular Material Processing Technology

Kawata has been the leading manufacturer of processing equipment for rubber and plastic since our foundation in 1935. We provide auxiliary equipment for plastic molding machines and its system engineering support. With our accumulated expertise and five core competencies: mixing, conveying, weighing, drying and temperature control, our technologies have come to be used in a wide range of field, including LCD, smart phones, batteries, food and cosmetics. As a specialist in labor-saving equipment at manufacturing sites, Kawata creates and offers products that match diverse needs in a wide range of fields with our leading-edge technology.

Company History

- 1935 Sep.** Kawata Manufacturing established by Masateru Kawata in Osaka, and started designing and manufacturing machines and molds for rubber goods production.
- 1949 Mar.** Started manufacturing plastic processing machines ahead of development of the chemical industry
- 1951 Jul.** Incorporated and changed the corporate name to Kawata Manufacturing Co., Ltd.
Appointed Masateru Kawata as the first president
- Oct.** Developed extruders and extrusion-related equipment for manufacturing pipes, corrugated plates, sheets, etc.
- 1962 Jun.** Began production of Super Mixer (high-speed fluid mixing kneader)
- Oct.** Obtained the utility model right of Auto Loader (automatic loader) and began the high-volume production
- 1963 Mar.** Opened Tokyo Office in Tokyo
- 1968 Apr.** Established Sanda Factory in Hyogo
- 1970 Jan.** Entered into a technological partnership with Conair Inc. in US for Auto Color (automatic colorant metering unit)
- 1972 Oct.** Opened Nagoya Office in Nagoya
- 1973 Mar.** Entered into a technological partnership with KraussMaffei Technologies GmbH in Germany for Super Grush Mixer
- Sep.** Entered into a technological partnership with Dr. Rodrich Graf (West Germany) for Challenger (dehumidifying dryer)
- 1980 Aug.** Entered into a technical cooperation with Toyo Ink Mfg. Co., Ltd. for Super Floater (vibrating mixer)
- 1985 Mar.** Changed the corporate name to Kawata Mfg. Co., Ltd.
- 1987 Jan.** Received a patent in Japan for Challenger (dehumidifying dryer) (Patent No. 160783)
- Aug.** Re-exported the technology of a resin drying system for CD to Conair Inc.
- 1988 May** Established Tokyo Factory in Saitama
- Sep.** Developed Dry Top (the world's first microwave continuous dryer), and won the Technology Prize in Osaka
- 1989 Jun.** Appointed Michinosuke Ota as president
- Jul.** Entered into a technological partnership with Axiomatics (current Trexel Inc.) for Axiometer (automatic continuous moisture meter)
- Sep.** Established a local subsidiary, KAWATA USA INC. in US
- Nov.** Established a local subsidiary, Kawata MF Singapore Pte. Ltd. (current Kawata Pacific Pte. Ltd.) in Singapore
- 1990 Jan.** Established THERMOTEQ INC. in Osaka
- 1991 Dec.** Registered with Japan Securities Dealers Association
- 1994 Jan.** Developed Challenger II, the world's first dehumidifying dryer with ADS ceramic as adsorbent
- 1995 Mar.** Established a local subsidiary, KAWATA (SHANGHAI) CO., LTD. in China
- Apr.** Entered into technical cooperation with TOYOTA MOTOR Corp. and TOYO INK MFG. CO., LTD. for Synchro Autocolor, a gravimetric feeder
- Jul.** Start marketing Synchro Autocolor
- 1996 Apr.** Opened a liaison office in Philippines
- Aug.** Established a local subsidiary, Kawata Thailand Co., Ltd. in Thailand
- Oct.** Developed the world's first material conveying and drying system for DVD
- 1997 Jul.** Established a local subsidiary, Kawata Machinery Manufacturing (Shanghai) Co., Ltd. in China
- 1998 Apr.** Obtained an exclusive distributorship to sell granulators from Rapid Granulator AB in Sweden and started marketing.
- Oct.** Completed Shanghai factory in China and started full-scale production of plastic processing machines
- 1999 May** Obtained ISO9001 certification for quality management
- Jun.** Appointed Michinosuke Ota as chairman and Toshimasa Ota as president
- Dec.** Established Kawata Techno Service Co., Ltd. in Osaka
- 2000 Feb.** Established a local subsidiary, Taiwan Kawata Co., Ltd. in Taiwan
- 2001 Jan.** Set up an automatic warehouse in Sanda Factory
- Mar.** Opened Shenzhen and Tianjin Office in China
- Dec.** Developed Super Add On Mixer, a waste plastic granulating and volume reduction system
- 2002 Feb.** Entered into partnership with Haruna Co., LTD. for Ecomak, an injection molding system for undried resins
- Sep.** Completed the second Shanghai factory in China
- 2003 Jan.** Established a local subsidiary, Kawata Machinery (HK) Ltd. in Hong Kong
- 2004 Mar.** Opened Suzhou Office in China
- Dec.** Listed on the JASDAQ Securities Exchange
- 2005 Apr.** Acquired all shares of ML Engineering Co., Ltd., as a wholly-owned subsidiary
- Oct.** Completed the third Shanghai factory in China
- 2006 Jun.** Appointed Naoto Yukawa as president
- 2008 Feb.** Obtained ISO14001 certification for environmental management
- Nov.** Announced newly developed products; a conveying, drying and feeding system for highly-functional film and self-discharging electrostatic eliminator at IPF
- 2009 Apr.** Developed "Challenge CES (Cost, Energy saving, Space saving)", and announced new products featuring CES
- 2010 Jun.** Entered into a business tie-up with AAA Machine Co. Ltd. to expand sales of powder-related and nanotechnology products to US
- Nov.** Set up a powder test center in Sanda Factory
- 2011 Apr.** Announced Zeno Filter, eliminator, and Fines Separator, particle eliminating separator, at POWTEX Osaka
Established P.T. Kawata Indonesia in Indonesia
- Sep.** Entered into a partnership with Akatake Engineering Co., Ltd. to expand sales of powder-related equipment
- Oct.** Commenced operations of P.T. Kawata Indonesia
- 2012 Apr.** Acquired all shares of Reiken Inc. as a wholly-owned subsidiary
- May** Completed new Osaka Factory in Osaka to expand the scale
- 2013 Jun.** Listed on the Second Section of the Tokyo Stock Exchange
Appointed Hidenori Shirai as president
- Jul.** Established a local subsidiary, Reiken (Thailand) Co., Ltd. in Thailand
- 2014 Jun.** Established PT.Kawata Marketing Indonesia in Republic of Indonesia.
- 2015 Sep.** Changed the number of shares per share unit from 1,000 shares to 100 shares.
Relocated Kawata Machinery Manufacturing (Shanghai) Co., Ltd. to a new factory in Shanghai.
- 2016 Jun.** Transferred to a Company with an Audit and Supervisory Committee.
- Nov.** Established a local subsidiary, Kawata-Machinery Mexico S.A. DE C.V. in Mexico.
- 2018 Mar.** Assignment to the First Section of the Tokyo Stock Exchange.
- 2019 Jan.** Appointed Wataru Shiraishi as president
- 2020 Feb.** Established a local corporation, "Kawata Machinery Vietnam Co., Ltd." in the Socialist Republic of Vietnam.

TOP MESSAGE from President

“Offering products and service that impress our customers, responding quickly to the demands of the market and society”

In 1935, we started life as KAWATA MANUFACTURING. Beginning with parts making under a subcontract, we produced a rubber tube extruder as our first product in 1938. In anticipation of the growing demand for plastics after the war, we began to develop and manufacture plastic extruders and auxiliary equipment for plastic molding factories, and actively pursued technical tie-ups with European and American manufacturers, which formed foundations for our current products.

It is the spirit since the company's foundation that has supported our growth.

1. Offering products and service to support requirements of customers and society
2. Challenging ourselves to pursue possibilities without experience or knowledge
3. Taking action speedily to make a try
4. Management attitude of making progress with employees

The environment surrounding the manufacturing industry is about to change significantly as the economic globalization and information society develop. In this situation, we will make steady progress toward our goal, keeping our spirit since its foundation in mind.

New materials and neo functional materials have been still developed along with diversification of plastic products. The uses of plastic products are expected to expand continuously on a worldwide basis, implementing environmental measures, such as recycling, improved durability, etc. In addition, there has been a growing demand for more labor savings at production sites.

Listening closely to the needs of our customers, we will make contributions to safer and more affluent lives for people in the world, as well as enhance our shareholders and enterprise value, by offering products and service to ensure customer satisfaction and solutions leading to improvement in production activities based on our long-accumulated technology.

Manufacturing strength for a wide range of fields from versatile plastic to medical and food products

Plastics are used in many fields from PET bottles to the aerospace industry. They have become remarkably sophisticated in their performance, offering such features as heat resistance, high strength, light weight, electrical insulation, and dimensional stability. With such properties, engineering plastics are used today in automobiles, electronic equipment, information storage media, and many other areas. Our lives are enriched by products made with powder and granular material processing technologies, particularly through the manufacturing of medical supplies and processing of various types of food. KAWATA provides systems engineering and manufacturing equipment in a great many fields.

Challenge CES from KAWATA—always a step ahead of the times with its technologies



“Challenge CES”
KAWATA's eco mark

As a company with social awareness, we are determinedly pursuing environmentally friendly product development to help slow global warming. The best way to accomplish environmental conservation is by making environmental products that the market will accept and use.

C is for Cost. We set the prices for our products at reasonable levels. If the features have improved we keep the price the same. If the features are the same, we make the price low.

E is for Energy. To reduce carbon emissions, we improve energy efficiency through waste heat control or other types of energy-saving design.

S is for Space. We are making equipment more compact to save space, at the same time using less iron, stainless steel, etc. in the production.

KAWATA develops cutting-edge products with the promotion of Challenge CES in every area of the company from design and production to sales and management, as well as improving product quality.

Using in-house standards, products that have achieved a 10% or greater improvement over previous models in cost, energy, and space savings are allowed to bear the Challenge CES mark.



President **Wataru Shiraishi**

KAWATA's Powder & Granule Processing Equipment

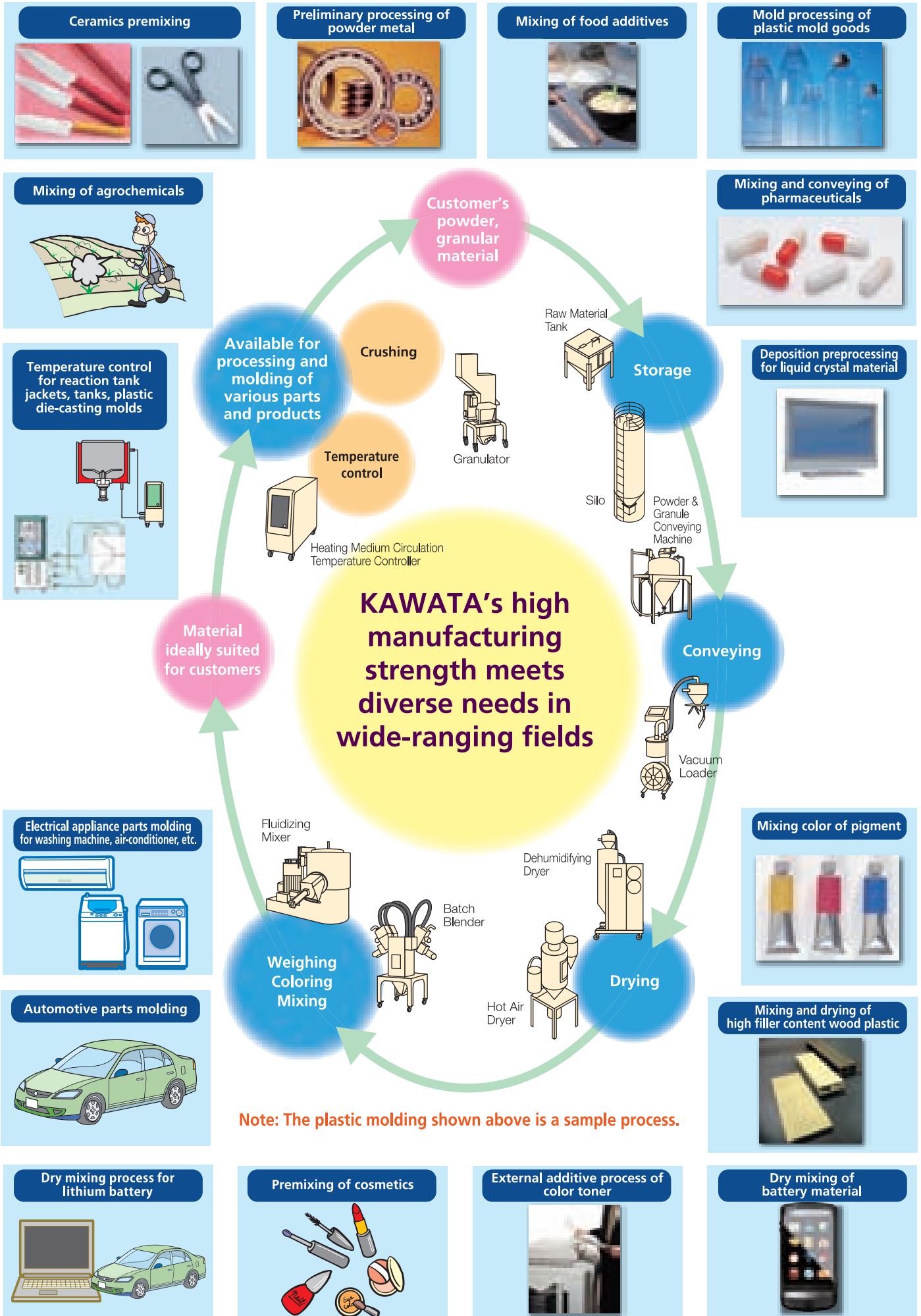

Processing Machines and Systems to Establish Fully Automated Factories

Selectronic system to meet increasingly advanced user needs (granules)

In KAWATA's proprietary Selectronic system, units of each process are connected to establish fully automated plastic molding factories. In addition to versatile Dryer and Autocolor, the adoption of Autobutor improves availability, focusing on a flexible manufacturing system (FMS) to meet advanced user needs.

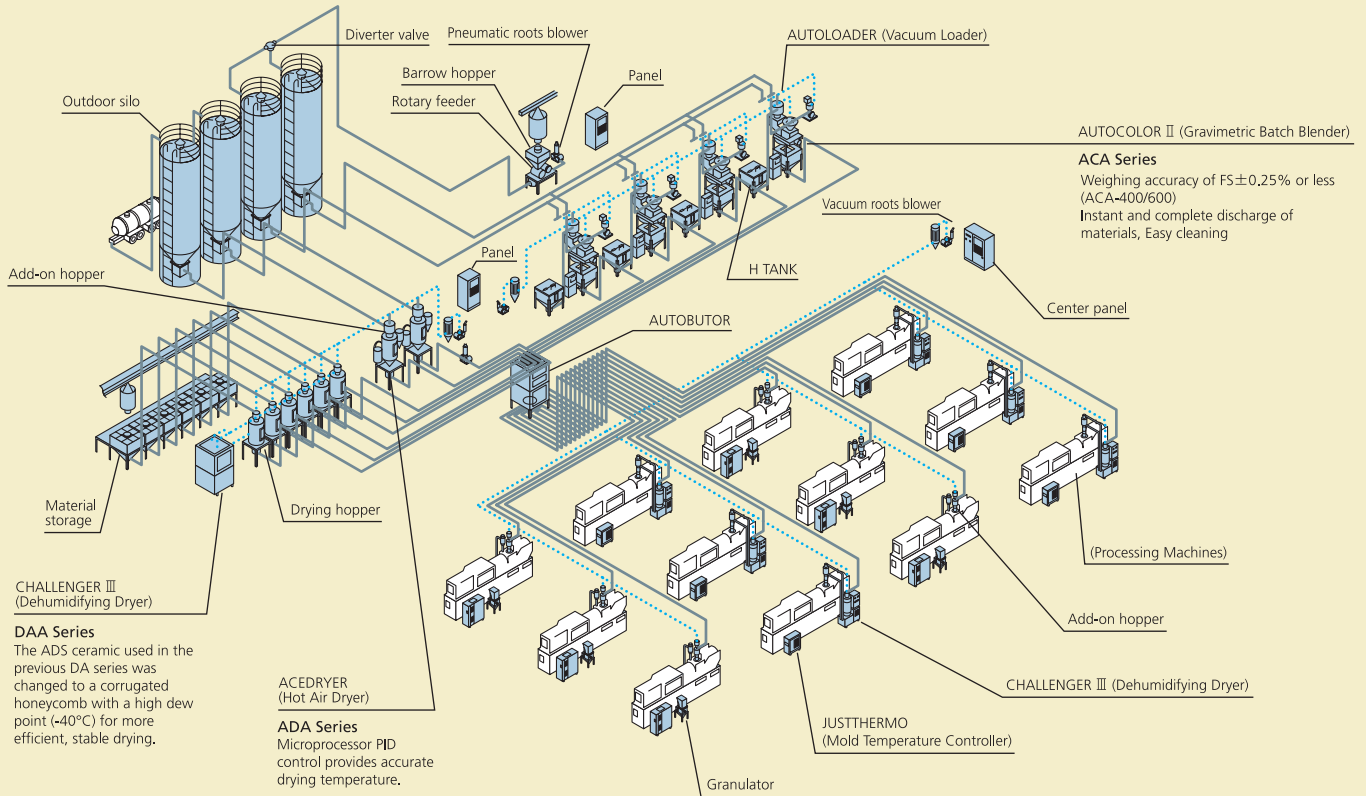
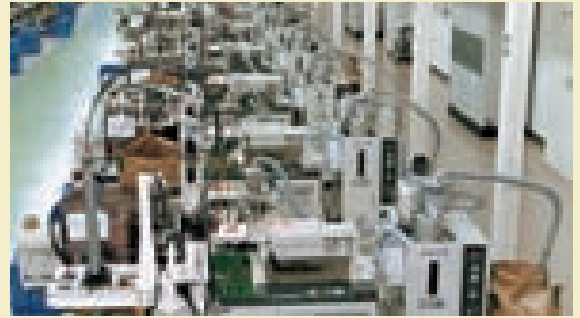

Storage



Material Storage SILO

Conveying



Vacuum Loader AUTOLOADER

Drying

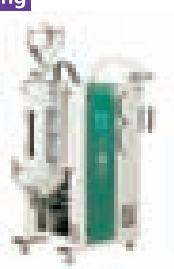

Dehumidifying Dryer CHALLENGER III

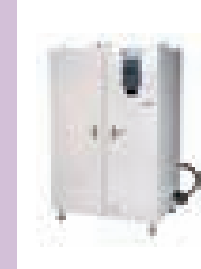

Dehumidifying Dryer CHALLENGER III

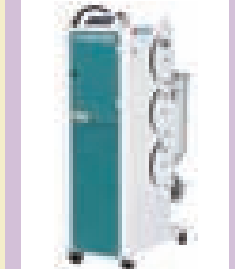

Nitrogen Dryer M STABILIZER

Blending



Gravimetric Batch Blender AUTOCOLOR LIMITED



Gravimetric Batch Blender AUTOCOLOR II

Granulation



Low Speed Granulator G MASTER

Temperature Control (Mold)



Heating Medium Circulation Temperature Controller JUSTTHERMO



Processing Machines and Systems to Establish Fully Automated Factories

Fully automated blending system to rationalize a production process (powder)

KAWATA's technology has integrated each unit into a complete system for the automation of a production process. The automated blending process helps rationalize production and keep the production environment clean.



Powder and granule mixing plant



Powder and granule mixing system panel

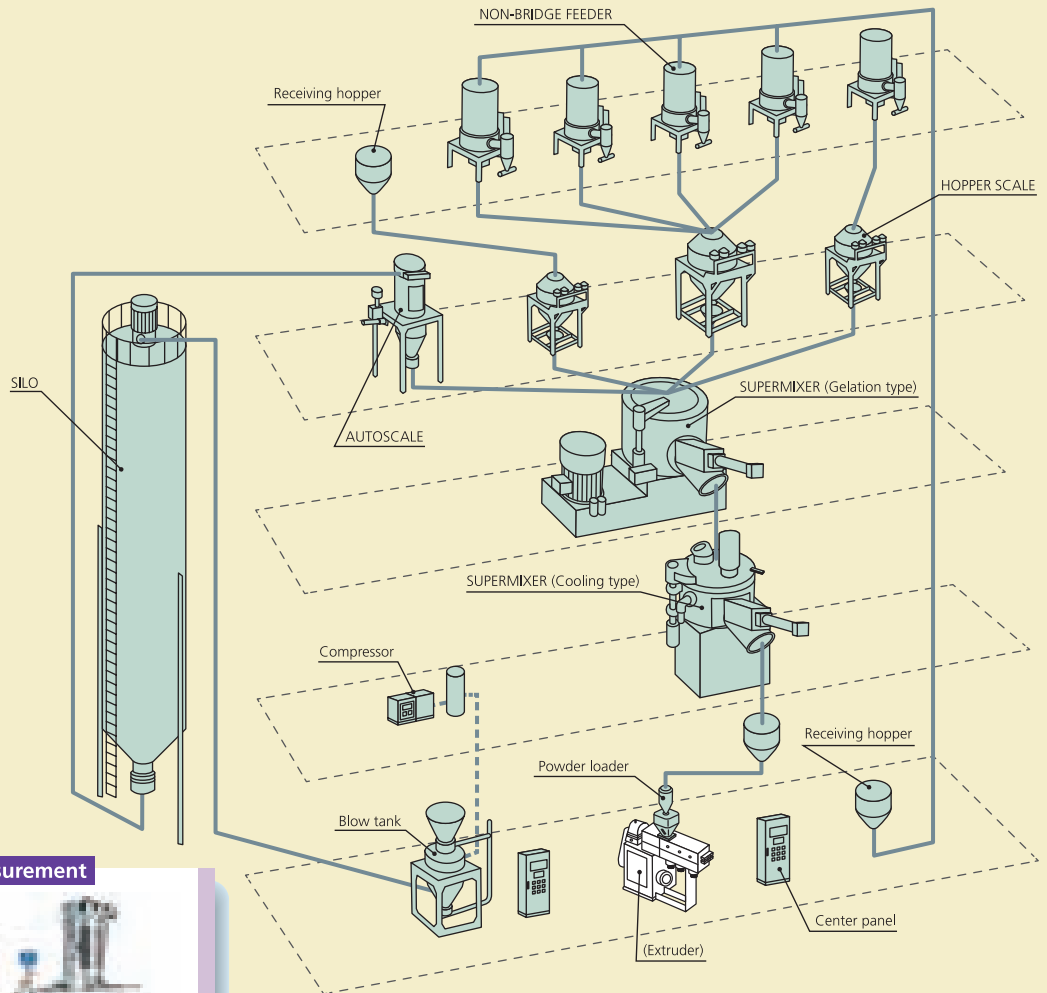

Storage



Material Storage
SILO

Measurement

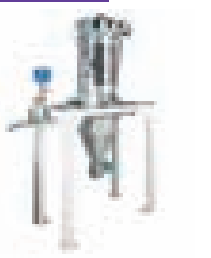

Conveying and Weighing Device
AUTOSCALE

Measurement

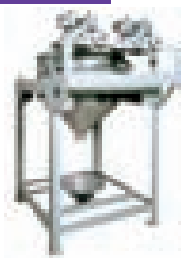

Weighing and Feeding Device
HOPPER SCALE

Measurement

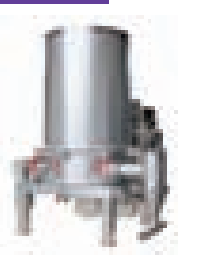

Weighing and Feeding Device
NON-BRIDGE FEEDER

Mixing

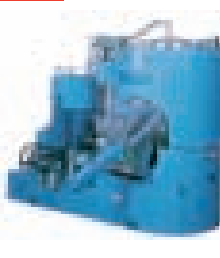

High Speed Fluidizing Mixer
SUPERMIXER (Gelation type)

Mixing/Cooling

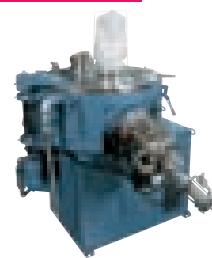

Cooling Mixer
SUPERMIXER (Cooling type)

Temperature control

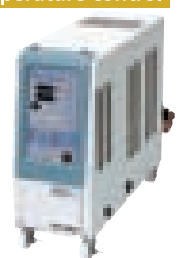

Heating Medium Circulation
Temperature Controller
JUSTTHERMO



Powder Processing Equipment and Systems

Since the founding of our company, we have offered high speed fluidizing mixers (Supermixers) and other key equipment needed by powder processing plants. We provide top-notch solutions by combining different types of equipment and using our long-established expertise in powder engineering to help customers with needs in this area. Please contact us to discuss your powder processing needs.

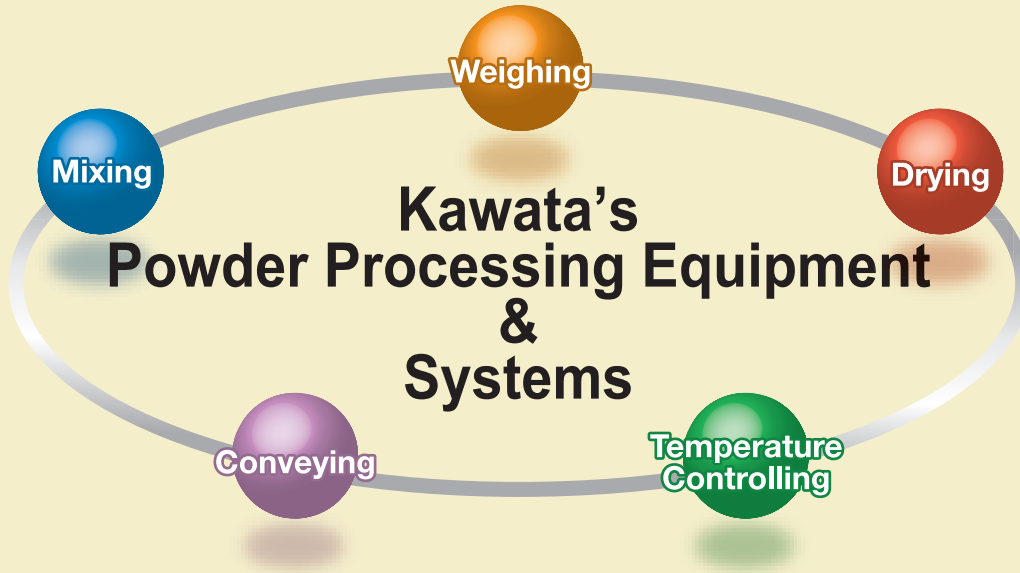

“Mixing”, this process is essential for every kind of industries. “Mixing uniformly to the limit”, “mixing in a short time” and “mixing slowly and quietly”—we will think of and offer technology appropriate to purposes and conditions to customers.



The easiest and most efficient conveying systems have been developed by our comprehensive technology in quest for compact design and energy conservation.



“Accurate” is the keyword. Our weighing devices with the utmost accuracy are easy to use, particularly suited for control panels placing emphasis on human interface.



Drying is an important process to control moisture, volatile portions or unnecessary components of materials, which has an influence on the next process.



The temperature controllers are designed to not only heat and cool in the production process but accurately maintain temperature of a medium (fresh water or oil) at the set point to control temperature of a target material (jackets or various rolls).

Mixing Nanoperion

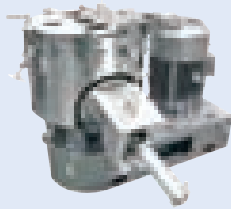

- Features**
- ① High-speed spec, better mixing and dispersal
 - ② Dry mixing of nanosize particle
 - ③ High shearing force, fine grinding

- Applications**
- | | |
|--------------|------------------------|
| Plastic | Fine chemicals |
| Rubber | Batteries |
| Ceramic | Construction materials |
| Powder paint | Glass |

Mixing Supermixer

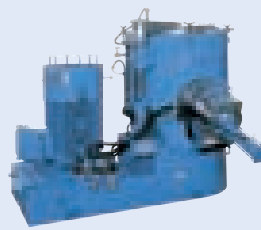

- Features**
- ① Uniform mixing in a short time
 - ② A wide range of blades for various materials and treatments
 - ③ A wide range of models appropriate to purposes and throughput
 - ④ A wide choice of options; wear resistance, decompression, chopper and heating and cooling unit
 - ⑤ Designed for easy cleaning and maintenance

- Applications**
- | | |
|--------------|------------------------|
| Plastic | Fine chemicals |
| Rubber | Batteries |
| Ceramic | Construction materials |
| Powder paint | Glass |

Conveying Blowtank

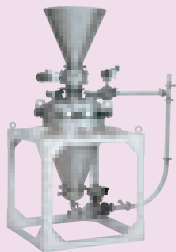

- Features**
- ① High-density conveying system for efficient conveying
 - ② Minimized risk of fracture at conveying material
 - ③ Reduced wear and tear inside the piping

- Applications**
- | | |
|---------------|----------------|
| Plastic | Fine chemicals |
| Ceramic | Batteries |
| Agrochemicals | |

Conveying Powderloader



- Features**
- ① Easy disassembly and cleaning
 - ② Lightweight modules
 - ③ Designed for all conveying methods
 - ④ Nozzle to reduce the load depending on material

- Applications**
- | | |
|---------------|----------------|
| Plastic | Fine chemicals |
| Ceramic | Batteries |
| Agrochemicals | |

Weighing Wingscaler



- Features**
- ① Weighing capacity 10kg~120kg/h, 1kg~10kg/h (Bulk density = 1.0kg cm³)
 - ② High accuracy, Realized setting value +/-0.5wt% accuracy (Accuracy depends on material)
 - ③ Can be used for various powder material!

- Applications**
- | | |
|---------|----------------|
| Plastic | Agrochemicals |
| Ceramic | Fine chemicals |
| Food | Batteries |

Weighing Finesbit



- Features**
- ① Measuring range 100g~1000g/hr
 - ② Microscale feeding for ultrafine powder
 - ③ High accuracy Set value +/-1~3wt.% (Accuracy varies with types of measured material)

- Applications**
- | | |
|-----------|----------------|
| Food | Fine chemicals |
| Cosmetics | Batteries |

Drying Mixer and Temperature Controller

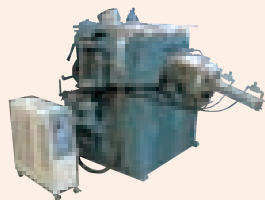

- Features**
- ① Efficient mixing under optimum temperature control
 - ② Cooling by chillers in case of inappropriate temperature rise
 - ③ External heating effective for additional drying during mixing

- Applications**
- | |
|------------------------|
| Plastic |
| Fine chemicals |
| Construction materials |

Temperature Controlling Roll Temperature Controller



- Features**
- ① Medium circulation throughout the waterway by large flow and high pressure
 - ② Two mediums of water and oil
 - ③ Process temperatures from 40°C up to 320°C
 - ④ Highly accurate temperature control
 - ⑤ Programmable control for various operations

- Applications**
- | |
|-----------|
| Plastic |
| Ceramic |
| Batteries |

Jacket Temperature Controller

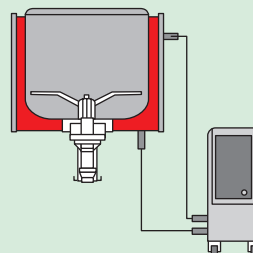

- Features**
- ① Low-pressure pump for various types of jackets
 - ② Highly accurate temperature control
 - ③ Programmable control for various operations
 - ④ Process temperatures from 7°C up to 320°C

- Applications**
- | | | |
|-----------------|----------|------------------------|
| Food | Paint | Construction materials |
| Pharmaceuticals | Pigments | Fine chemicals |
| Feedstuff | Plastic | Cosmetics |
| Agrochemicals | Ceramic | Batteries |

Clean Dryer

Exploring various fields, such as rechargeable batteries, liquid crystal-related equipment, optical lenses, etc.

We at KAWATA successfully launched a dehumidifying resin dryer (product name: Challenger) in the Japanese market in 1973 ahead of our competitors. Since the launch of this product, we have developed a variety of highly reliable products to support plastic molding processes based on our persistent pursuit of technologies and abundant experience, to keep up with the advent of various engineering plastics.

Dryer for optical films (N₂ applicable)

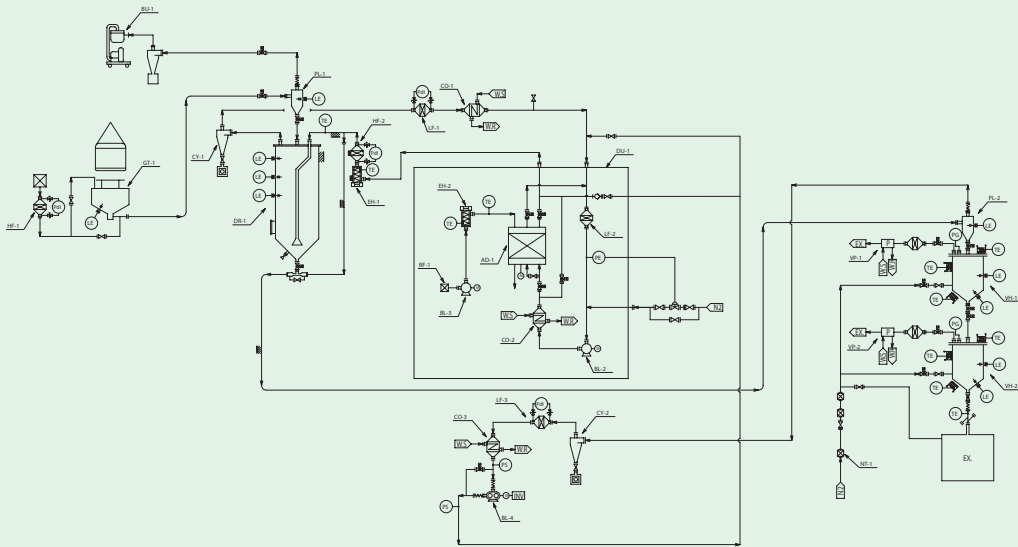

Intensified in-house test system

We will meet customers' requests for various drying tests with materials provided by customers.

- For establishment of drying conditions of newly-developed materials
- For drying process at low temperature and low dew point for materials that easily undergo fusion or blocking.
- For evaluation of drying process through N₂ circulation for the purpose of prevention of deterioration caused by oxidation, yellowing, etc.
- For stable crystallization without fusion or deformation of copolymer chips

We have established a system to conduct various drying tests such as the above, to meet various requests of customers.

We also offer various measuring instruments such as a moisture meter (based on the Karl Fischer method) and differential thermal analyzer to meet customers' requests.

Nitrogen dryer for optical lens and light guide plate molding processes (Continuous type)

M-STABILIZER-DO series

- Enables stable molding, free from damage to raw material
- Through control of materials, from raw material bags to molding machine
- Prevents yellowing with 99% or higher nitrogen concentration in machine



Technology Development and IP

KAWATA's technology development places top priority on customer satisfaction

Here are ideas and actions that create the future process technology



Technology Development: Starting with Market Analysis

"What do customers require and what are the current needs?" We at KAWATA get started by finding the answers to these questions. User opinions and contemporary needs derived from our steady market activities form the basis of KAWATA's highly innovative and technologically advanced products. Through Challenge CES (cost reduction, energy conservation, space savings), we are working to manufacture products that enable ideal conditions for factories that manufacture powder and granular material.



Personnel Rotation System: To Foster Engineers with Extensive Knowledge from R&D to Manufacturing

With an eye toward developing superior technologies, KAWATA adopts ideas and proposals from many quarters. We conduct research and development by working with plastic material users and molding compound manufacturers, and have working relationships with the Technology Research Institute of Osaka Prefecture, the Osaka Municipal Technical Research Institute, and Yamagata University. Naturally, for fostering human resources, we have adopted an interdepartmental personnel rotation system that our engineering staff is periodically involved in design and development of various products and systems so that they can have extensive knowledge and experience. From our market analysis our product development group is involved in industry-university joint research along with new product development, playing an important role in the company's present and future with our design department.

Advanced Development System: To Create the State of the Art

KAWATA has systematic testing facilities that enable our staff to develop high-precision processing equipment and systems that offer high productivity. In addition, our computer-integrated systems handle large amounts of multifaceted data to facilitate

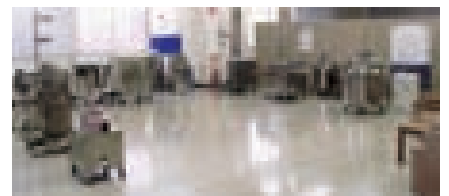

technological development. As we continue to conduct basic research, we remain enthusiastic about developing tomorrow's technology and products and also applied technology.

Intellectual Property Management with a Balance of Proactive and Protective Action

We have established a section that focuses exclusively on the proper management of KAWATA's intellectual property, from patents to utility models and trademarks. The section works with external organizations to acquire patents for products developed by KAWATA and performs internal reviews to ensure the absence of patent infringement. We work proactively on improving the value of KAWATA products.

Production

**Reliability—Synonym of KAWATA Brand:
Quick Supply of High-Quality and
High-Precision Products**

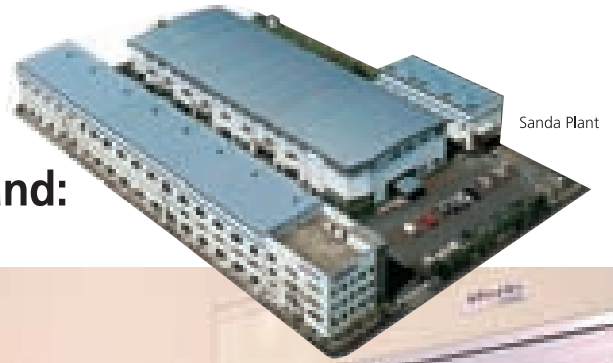

Total Production System: Result of Cross-divisional Cooperation

KAWATA's high-quality and high-precision products shipped from our production division are the embodiment of the cooperation with other divisions: the sales division provides information on customer demands that is later reflected in products; and the technology development division finds innovative technologies and designs new equipment and systems. The reliability of the KAWATA brand results from the cooperation of all departments.

Flexible Production Line: To Meet Higher Customer Demands

In order to deal with rapid changes in the industrial environment along with ever-increasing customer demands, we at KAWATA have promoted the construction of flexible production lines from our early days. KAWATA's total system of production employs an organic combination of different types of standalone equipment, such as processing equipment, batch blenders, and dehumidifying dryers. Such a system produces a focus on high quality, high accuracy, and cost reductions. Working on the basis of just-in-time production, we provide customers with a steady supply of cost-effective products from our factories in Sanda and Tokyo, our expanded Osaka and Shanghai factories, and our newly established Indonesia factory.

Pursuing High Quality and Environmental Measures with People and Technology

To ensure the reliability of our products, KAWATA has a computer-controlled system including measuring instruments in various points of the production lines for strict quality control. It is not until equipment passes a set standard that it can be placed on the market with KAWATA's name. Of course, it is individual people that support the quality control. Our strenuous efforts and insistence on complete quality control won us ISO 9001 certification in May 1999. In February 2008 we obtained ISO 14001 certification for environmental management in order for us to protect the environment by reducing CO₂ emissions and manufacturing eco-friendly products. KAWATA brings our products nearer to perfection with human and environment-friendly technologies.



Sales

Our highly knowledgeable sales engineers excel at consulting and offer added-value solutions



Our Sales Engineers

Our sales engineers offer extra value solutions based on various cases, as well as meet customers' requests. With the progress of times, Kawata sales staff with engineering skills keep an eye on the trend and make proposals ahead of times so as to offer long-lasting satisfaction to customers.

Reliable After-Sales Service

After-sales service staff stationed at each sales office offer attentive and rapid response in both Japan and foreign countries. We are available 24 hours a day to offer our domestic after-sales service by telephone.



Administration

Solid base for smooth and sound management by grasp of all kinds of real-time information on business activities

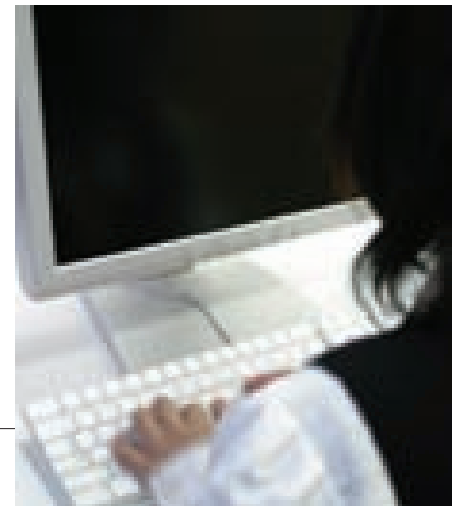

The Administrative Division, Supporting Corporate Social Responsibility

Kawata consistently strives to make a positive contribution to society through our products and services. The administrative division maintains the base for such activities by controlling the flow of information, money, goods and people through the use of information technologies with a company-wide online system, facilitating smooth and sound management. In addition, this division handles many key functions of drafting business plans, maintaining a sound financial position, adequately disclosing information, giving consideration to labor and safety and sanitation, abiding by regulations, promoting environmental protection, etc. — important force supporting and driving our business activities.

Creating a Pleasant Work Environment

The administrative division believes that creating a pleasant work environment allows KAWATA's employees to provide excellent products and services to customers. We are working toward establishing a highly useful personnel evaluation system to improve employee satisfaction and enhance personal growth through work.



KAWATA GLOBAL NETWORK

Overseas

Coexistence with the World: Heart and Technology

Overseas Bases: Recognition of Differences in Cultural Values

We understand that common knowledge differs from culture to culture, so we must seek to understand one another's values in order to succeed with our international strategy. We launched CONAIR KAWATA in the USA in July 1986, and later opened sales offices in North America, China, Thailand, Singapore, Malaysia, Taiwan, Indonesia, Philippines, and Vietnam, and plants in China, Indonesia and Thailand. With full respect for the cultural values of the people who work and live there, we will develop in a mutually complementary manner, leading to a fruitful coexistence which we are striving toward.

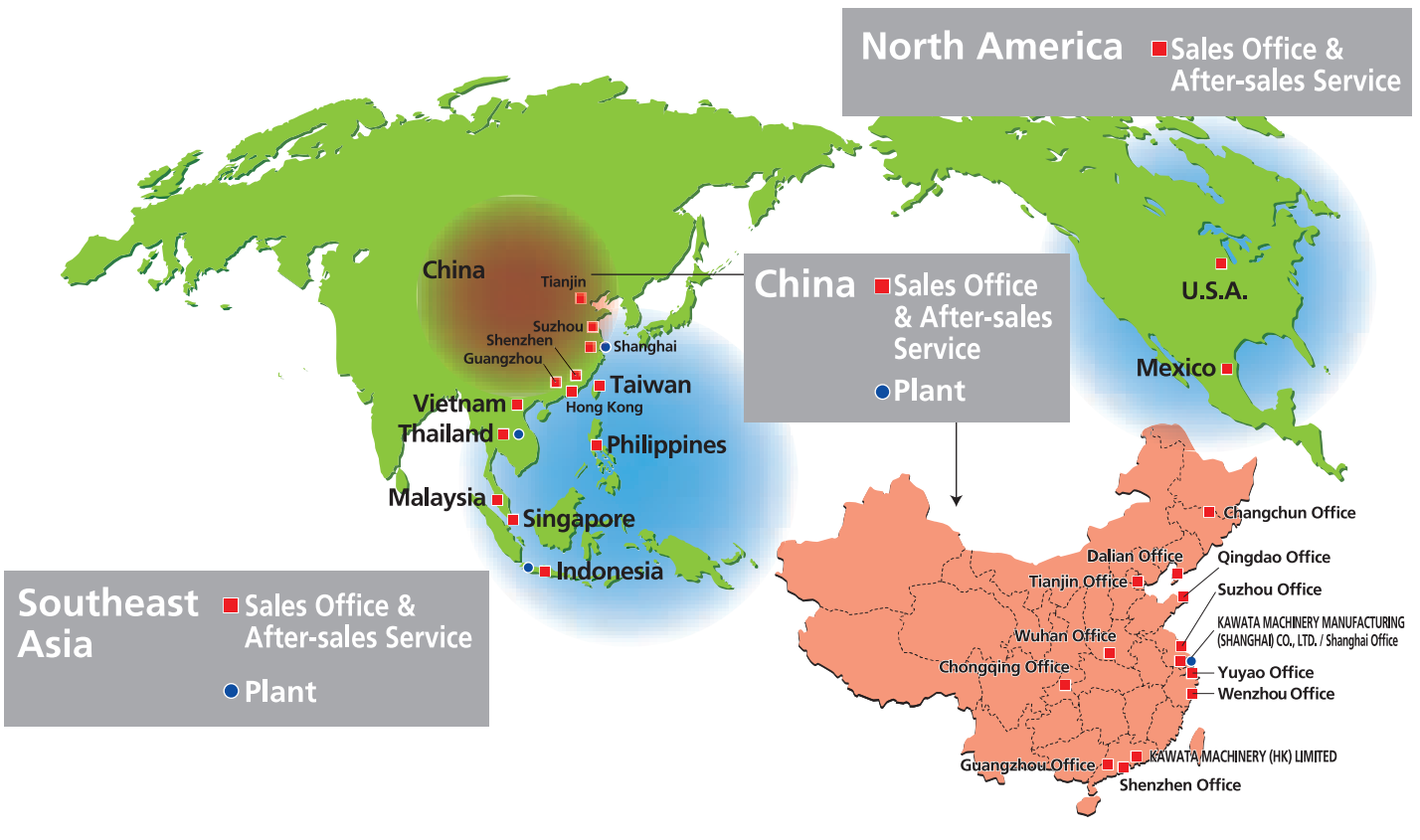

Overseas

- **U.S.A. Office :** KAWATA U.S.A., INC.
1701 E Woodfield Rd, Suite 630 Schaumburg, IL 60173, U.S.A.
- **Mexico Office:** KAWATA-MACHINERY MEXICO S.A.DE C.V.
"Business Park Conin", Lateral Norte de la Autopista 57 Mexico - Queretaro Km.201+100 El Marques, Queretaro.CP76246, Modulos 3 y 4
Phone: 52-442-277-4679 Fax: 52-442-277-4582
- **Singapore Office:** KAWATA PACIFIC PTE. LTD.
8, Kaki Bukit Road 2, #02-34 Ruby Warehouse Complex Singapore 417841
Phone: 65-6286-8817 Fax: 65-6846-8817
- **Thailand Office:** KAWATA (THAILAND) CO., LTD.
135/15-16 8TH FL., Amonphan 205 Tower 2 Soi Ratchadapisek 7 (Nathong), Ratchadapisek Road, Dindeang, Bangkok 10400 Thailand
Phone: 66-2-692-1331 Fax: 66-2-692-1332
- **Vietnam Office:** KAWATA MACHINERY (VIETNAM) CO., LTD.
REECO Building, 4th Floor, 98 Hoang Ngan Street, Trung Hoa Ward Cau GiayDistrict, Hanoi, Vietnam
Phone: 84-24-22250155 Fax: 84-24-22250156
- **Philippines Office:** KAWATA (THAILAND) CO., LTD. (Philippines Representative Office)
2nd Floor CJRS Parkview Bldg., Phase 5 Lot G&H, Rodeo Drive Laguna Bel Air2, Brgy. Don Jose, City of Sta. Rosa, Laguna
Phone: 63-917-312-0003
- **Malaysia Office:** KAWATA MARKETING SDN. BHD.
Lot 3986(F&G), Jalan Haruan 1, Oakland Industrial Park, 70300, Seremban, Negeri Sembilan, Malaysia
Phone: 60-6-765-6628 Fax: 60-6-765-6629
- **Indonesia Office:** PT. KAWATA MARKETING INDONESIA
Prince Center Building 6th. Floor Unit 0603 Jl. Jend. Sudirman Kav. 3-4 Jakarta Pusat 10220, Indonesia
Phone: 62-21-573-5232
- **Hongkong Office:** KAWATA MACHINERY (HK) LIMITED
Unit 902, 9/F, Lucky Commercial Center, No.103 Des Voeux Road West, Hong Kong
Phone: 852-3118-1326 Fax: 852-2545-0576 / 2857-2607

- **Taiwan Office:** TAIWAN KAWATA CO., LTD.
5F, No.37, Minzu Rd., Hsinchu City 300, Taiwan (R.O.C.) (Lion King Business Center)
Phone: 886-3-534-1847 Fax: 886-3-534-1848
- **Shanghai Office:** KAWATA MACHINERY MANUFACTURING (SHANGHAI) CO., LTD. / SHANGHAI OFFICE
No. 325, Yuandian Road, Xinzhuang Industry Zone, Minhang District, Shanghai 201108, China
Phone: 86-21-6289-8989 Fax: 86-21-6279-1266
- **Suzhou Office:** KAWATA MACHINERY MANUFACTURING (SHANGHAI) CO., LTD. / SUZHOU OFFICE
Rm. 204, Building 3, No.1099 Baodai West Rd., Suzhou New & Hi-Tech Industrial Development Zone, Suzhou, Jiangsu 215011, China
Phone: 86-512-6825-0628 Fax: 86-512-6825-0728
- **Tianjin Office:** KAWATA MACHINERY MANUFACTURING (SHANGHAI) CO., LTD. / TIANJIN OFFICE
Rm. 1102, Block C, New City Center, No.3 Wanhui Rd., Zhongbei Town, Xiqing District, Tianjing 300112, China
Phone: 86-22-2370-7800 Fax: 86-22-2370-7801
- **Shenzhen Office:** KAWATA MACHINERY MANUFACTURING (SHANGHAI) CO., LTD. / SHENZHEN OFFICE
Rm. 1902, Mei Lan Business Centre, Crossing of Xixiang Street and Quanjin Two Road, Shenzhen, Guangdong, 518101, China
Phone: 86-755-8229-5249 / 5250 Fax: 86-755-8229-5251
- **Guangzhou Office:** KAWATA MACHINERY MANUFACTURING (SHANGHAI) CO., LTD. / GUANGZHOU OFFICE
Rm. 1602, Block C4, no. 489 Xingang Zhong Road, Haizhu District, Guangzhou, Guangdong, 510310, China
Phone: 86-20-3402-5200 Fax: 86-20-3402-5183
- **Offices in China (refer to map above)**
- **Thailand Plant:** REIKEN (THAILAND) CO., LTD.
136 Moo 1 Hi-tech Industrial Estate, Tambol Bannlane, Amphur Bangpa-in, Ayutthaya Province 13160
Phone: 66-35-314-300 Fax: 66-35-314-301
- **Indonesia Plant:** PT.KAWATA INDONESIA
Jababeka Techno Park KIJ III E2C Pasir Gombang Cikarang Utara Bekasi Jawa Barat 17550 Indonesia
Phone: 62-21-89844560 Fax: 62-21-89844559
- **China Plant:** KAWATA MACHINERY MANUFACTURING (SHANGHAI) CO., LTD.
No. 325, Yuandian Road, Xinzhuang Industry Zone, Minhang District, Shanghai 201108, China
Phone: 86-21-3329-0099 Fax: 86-21-3329-0096

Offices and Factories

Domestic

Head Office	Daiichi Kyogyo Bldg., 1-15-15, Awaza, Nishi-ku, Osaka 550-0011, Japan Phone: 81-6-6531-8211 Fax: 81-6-6531-8216
Head Office(Osaka Sales Department)	Phone: 81-6-6531-8011 Fax: 81-6-6531-8216
Sendai Office	2-5-14, Koriyama, Taihaku-ku, Sendai, Miyagi 982-0003, Japan
Sendai Technical Service Department	Phone: 81-22-308-6361 Fax: 81-22-308-6364
Kita-Kanto Technical Service Department	1460-3, Egimachi, Takasaki, Gunma 370-0046, Japan Phone: 81-27-310-1701 Fax: 81-27-321-4353
Saitama Office	5-5-13, Ryoke, Kawaguchi, Saitama 332-0004, Japan Phone: 81-48-224-0008 Fax: 81-48-224-0090
Tokyo Office	Shinkawa Musashiya Building, 1-2-10 Shinkawa, Chuo-ku, Tokyo 104-0033, Japan Phone: 81-3-3523-5680 Fax: 81-3-3523-5682
Minami-Kanto Office	TYG Daini Izumicho Bldg., 14-2, Izumimachi, Atsugi, Kanagawa 243-0013, Japan
Minami-Kanto Technical Service Department	Phone: 81-46-229-6828 Fax: 81-46-229-6810
Shizuoka Office	4-1-26, Nakada, Suruga-ku, Shizuoka 422-8041, Japan
Shizuoka Technical Service Department	Phone: 81-54-287-2040 Fax: 81-54-287-2344
Nagoya Office	1-2-22, Ozono, Higashi-ku, Nagoya 461-0021, Japan Phone: 81-52-918-7510 Fax: 81-52-911-3450
Nagoya Technical Service Department	Phone: 81-52-918-7530 Fax: 81-52-911-7490
Hiroshima Office	KDX Hiroshima Bldg., 2-15, Kinyacho, Minami-ku, Hiroshima 732-0825, Japan
Hiroshima Technical Service Department	Phone: 81-82-568-0541 Fax: 81-82-263-5492
Kyushu Office	Hakata Sun-City Bldg. 2, 3-11-28, Hakata Station Higashi, Hakata-ku, Fukuoka 812-0013, Japan
Kyushu Technical Service Department	Phone: 81-92-412-6767 Fax: 81-92-412-6591
Sanda Plant(Design Department)	501-17, Miyanomae, Fukushima, Sanda, Hyogo 669-1313, Japan Phone: 81-79-563-6911 Fax: 81-79-563-6917
Sanda Plant (Manufacturing Department (Purchasing Section))	501-17, Miyanomae, Fukushima, Sanda, Hyogo 669-1313, Japan Phone: 81-79-563-6941 Fax: 81-79-563-4687
Sanda Plant (Intellectual Property and Development Department)	501-17, Miyanomae, Fukushima, Sanda, Hyogo 669-1313, Japan Phone: 81-79-563-6201 Fax: 81-79-563-6244
Sanda Plant(Quality Assurance Room)	501-17, Miyanomae, Fukushima, Sanda, Hyogo 669-1313, Japan Phone: 81-79-563-6991 Fax: 81-79-563-6947
Tokyo Plant	5-5-13, Ryoke, Kawaguchi, Saitama 332-0004, Japan
Tokyo Technical Service Department	Phone: 81-48-224-4447 Fax: 81-48-224-0153
Osaka Plant	5-2-10, Minamitsumori, Nishinari-ku, Osaka 557-0063, Japan
Osaka Technical Service Department	Phone: 81-6-6657-0858 Fax: 81-6-6657-0894

Company Profile

Name	KAWATA MFG Co., Ltd.
Representative	Wataru Shiraishi, President
Established	September 10, 1935
Capital	977,140,000 JPY
Major shareholders	KAWATA Kyoshinkai, Kawata Employee Shareholding Association, MUFG Bank, Ltd.
Yearly sales	21,100,000,000 JPY (FY 2020, March, Consolidated basis)
Business line	Design and manufacturing of powder and grain processing equipment and systems
Number of employees	850 (FY 2020, March, Consolidated basis)
Board of directors	President, Representative Director: Wataru Shiraishi Director, Operating Officer: Hidenori Shirai Director, Operating Officer: Takayuki Shiba Director: Tsunehiro Fujisaka Director, Full-Time Audit and Supervisory Committee Member: Hiroshi Watanabe Director, Audit and Supervisory Committee Member: Yoshinobu Ito Director, Audit and Supervisory Committee Member: Kazuo Iizuka Operating Officer: Toshiro Hashimoto Operating Officer: Hitoyoshi Yoshida Operating Officer: Hitoshi Kimizu Operating Officer: Masamichi Yano
Major banks	MUFG Bank, Ltd., Resona Bank Ltd., The Nanto Bank, Ltd., Mitsubishi UFJ Trust & Banking Corp.
Professional associations	The Osaka Chamber of Commerce & Industry Osaka Prefectural Industrial Association Osaka Industrial Research Association Japan Plastic Machinery Association Plastics Technology Association Plastics Molding Process Institute Japan Society of Plastics Technology East and West Japan Plastic Products Industrial Associations Japan Powder Industrial Technology Association Japan Bioplastics Association
Main business connections	<p>■Trading companies and machine manufacturers Daido Trading Co., Ltd., Daihan Co., Ltd., Daiichi Jitsugyo Co., Ltd., Denka Consultant & Engineering Co., Ltd., FANUC Corporation, Fuji Create Co., Ltd., Goyo Co., Ltd., Hamada Kakoki Hambai K.K., Hitachi Zosen Corporation, Inter plas Co., Ltd., Itochu Corporation, Kanematsu KGK Corporation, KISCO LTD., Marubeni Corporation, Mitsubishi Corporation, Mitsui & Co., Ltd., Nagase & Co., Ltd., Niigata Machine Techno Co., Ltd., Nikko YPK Shoji Co., Ltd., Nissei ASB Machine Co., Ltd., Nissei Plastic Industrial Co., Ltd., Okaya & Co., Ltd., Pla Matels Corporation, Roboshot Sales Co., Ltd., Shibaura Machine Co., Ltd., Sodick Co., Ltd., Sojitz Corporation, Sumitomo Shoji Machinex Co., Ltd., Sumitomo Heavy Industries, Ltd., The Japan Steel Works, Ltd., Toyo Corporation, Toyo Machinery & Metal Co., Ltd., Toyo Plastics Co., Ltd., Toyota Tsusho Corporation, U&M Plastic Solutions Co., Ltd., Ube Industries, Ltd., Toyotsu Machinery Corporation, Ushio Lighting, Inc., Yamazen Corporation Yuasa Trading Co., Ltd.</p> <p>■Customers Achilles Corporation, Alps Electric Co., Ltd., Aronkasei Co., Ltd., Asahi Kasei Corporation, Asahi Yukizai Corporation, Bando Chemical Industries, Ltd., Bridgestone Corporation, C. I. Takiron Corporation, Canon Inc., Chuo Kagaku Co., Ltd., CKD Corporation, Dai Nippon Printing Co., Ltd., Daihatsu Motor Co., Ltd., Daika Kogyo Co., Ltd., DaikyoNishikawa Corporation, Denka Co., Ltd., Denso Corporation, DIC Corporation, FP Corporation, Fujifilm Corporation, Furukawa Electric Co., Ltd., Gifu Plastic Industry Co., Ltd., Hiroshima Kasei, Ltd., Hitachi Chemical Company, Ltd., Hitachi, Ltd., Hokkai Can Co., Ltd., Honda Motor Co., Ltd., House Foods Corporation, HOYA Corporation, Ichikoh Industries, Ltd., Idemitsu Kosan Co., Ltd., IHI Corporation, J.S.T. Mfg. Co., Ltd., Japan Aviation Electronics Industry, Ltd., JVC Kenwood Corporation, Kaneka Corporation, Kao Corporation, Kirin Company, Limited, Kobe Steel, Ltd., Kodama Plastics Co., Ltd., Koito Manufacturing Co., Ltd., Konica Minolta, Inc., Kubota Chemix Co., Ltd., Kuraray Co., Ltd., Kyocera Corporation, Lotte Co., Ltd., Maezawa Kasei Industries Co., Ltd., Maxell, Ltd., Mazda Motor Corporation, Meiji Co., Ltd., Mitsubishi Chemical Corporation, Mitsubishi Electric Corporation, Mitsubishi Motors Corporation, Mitsuboshi Belting Ltd., Mitsui Chemicals, Inc., Moonstar Company, Morinaga & Co., Ltd., Nanjo Auto Interior Co., Ltd., NEC Corporation, Nidec Corporation, Nikon Corporation, Nipro Corporation, Nissan Motor Co., Ltd., NUC Corporation, Okura Industrial Co., Ltd., Olympus Corporation, Optes Inc., Otsuka Pharmaceutical Co., Ltd., Otsuka Techno Corporation, Panasonic Corporation, Polyplastics Co., Ltd., Ricoh Company, Ltd., Sanko Co., Ltd., Sekisui Chemical Co., Ltd., Sharp Corporation, Shin-Etsu Polymer Co., Ltd., SMC Corporation, Sony Corporation, Stanley Electric Co., Ltd., Subaru Corporation, Sumitomo Chemical Co., Ltd., Sumitomo Electric Industries, Ltd., Sumitomo Metal Industries, Ltd., Suzuki Motor Corporation, Taiyo Yuden Co., Ltd., Takeda Pharmaceutical Company Limited, Takeuchisangyo Corporation, TDK Corporation, Teijin Limited, Tenma Corporation, Terumo Corporation, Tokai Rika Co., Ltd., Toppa Printing Co., Ltd., Toray Industries, Inc., Toshiba Corporation, Toyo Cloth Co., Ltd., Toyo Seikan Co., Ltd., Toyobo Co., Ltd., Toyoda Gosei Co., Ltd., Toyota Motor Corporation, Unitika Ltd., Yamaha Corporation, Yamaha Motor Co., Ltd., Yamasa Corporation, Yoshino Kogyosho Co., Ltd., Zeon Corporation</p>

Website: <https://www.kawata.cc>

